

No.	Plan	Article	Qty
1	XP02994	GP22600	2
2	XP03285	2996960	1
3	YP08246	2611600	1
4	YP08247	2611700	1
5	XP03428	2658600	1
5*	YP08248	2611800	1
6	XP03429	2658900	1
6*	YP08249	2611900	1
7	XP03089	GP24000	1
8	XP03090	GP24100	1
9	M4x20	1907480	2
10	DIN471 9	2996616	4
11	X005748	1914355	0,2
12	M4 DIN985	1001678	2

\*Alternative  
 Assembly instruction S-PL.40.07

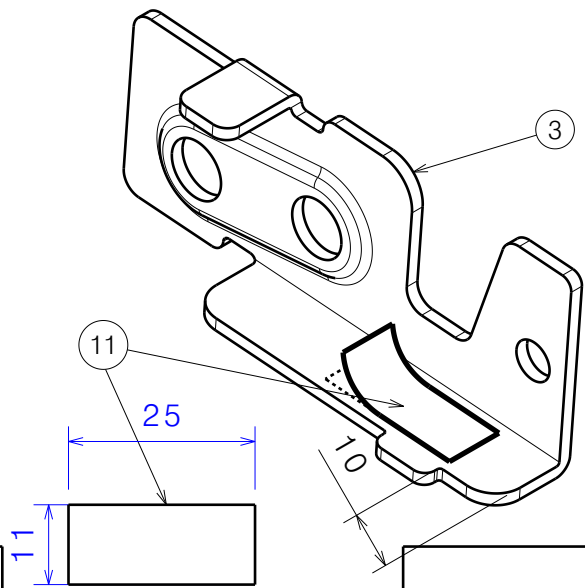

Method PL		
Procedure	Description	Tool
Assemble	Mounting Caliber	M600-034

NOTICE: THE INFORMATION CONTAINED ON THIS DRAWING IS PROPRIETARY TO VERMEIREN GROUP AND SHALL NOT BE DISCLOSED IN WHOLE OR IN PART, OR USED FOR ANY DESIGN OR MANUFACTURE, EXCEPT WHEN SUCH USER POSSESSES DIRECT WRITTEN AUTHORISATION FROM VERMEIREN GROUP.

ROTARY LATCH GEMINI 2020			
Scale:	Drafted	Verified	Confirmed
1:1	09.03.2021	03.02.2026	03.02.2026
Initials	OY	KA	AZ

---

Plan No.  
 EP00517/F